

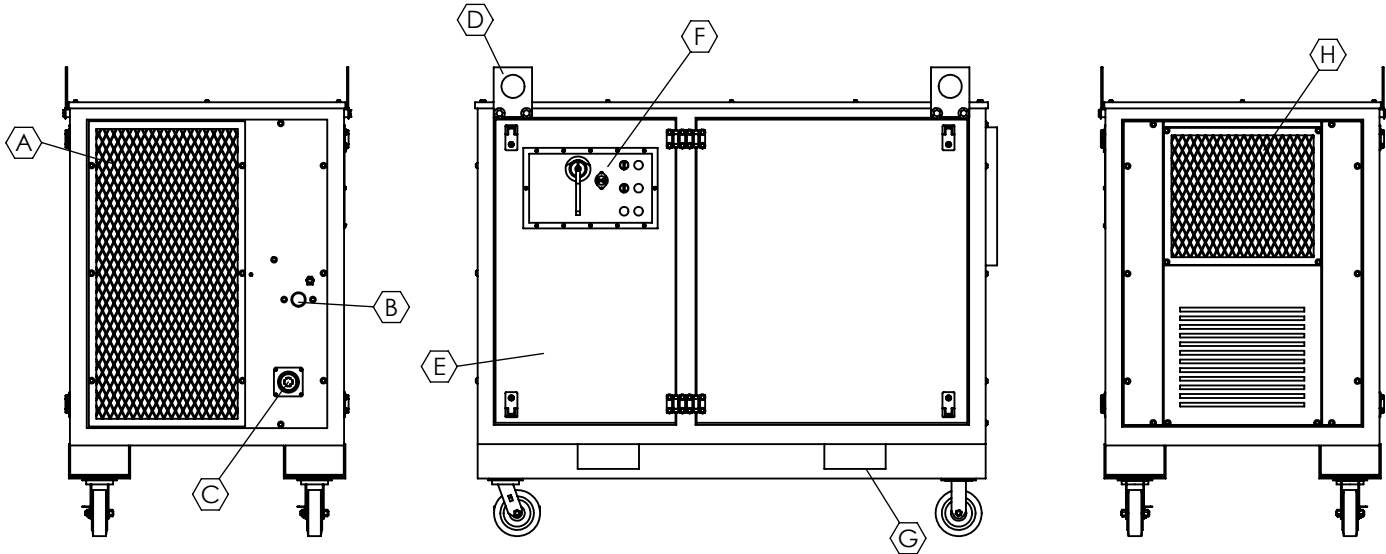

FMA-1500



SPECIFICATIONS:

POWER SUPPLY	230V/1PH/60Hz/25A
HEAT CAPACITY	200,000 - 1,500,000 BTU/HR
AIR FLOW	8,800 CFM
AIR OUTLET	20.5" W X 18" H

FUEL SUPPLY:

NATURAL GAS	5 PSI
PROPANE	5 PSI
CONNECTION	1-1/4" NPT

DIMENSIONS:

LENGTH	69 in
WIDTH	37 in
HEIGHT	61 in
WEIGHT	1270 lbs

- A INLET SCREEN
- B 1-1/4" GAS INLET
- C ELECTRICAL CONNECTION
- D LIFTING EYES
- E SERVICE ACCESS DOOR
- F CONTROL PANEL
- G FORK POCKETS
- H AIR DISCHARGE

FUEL CONSUMPTION:

NATURAL GAS	1500 CFH
PROPANE	16.4 GPH