

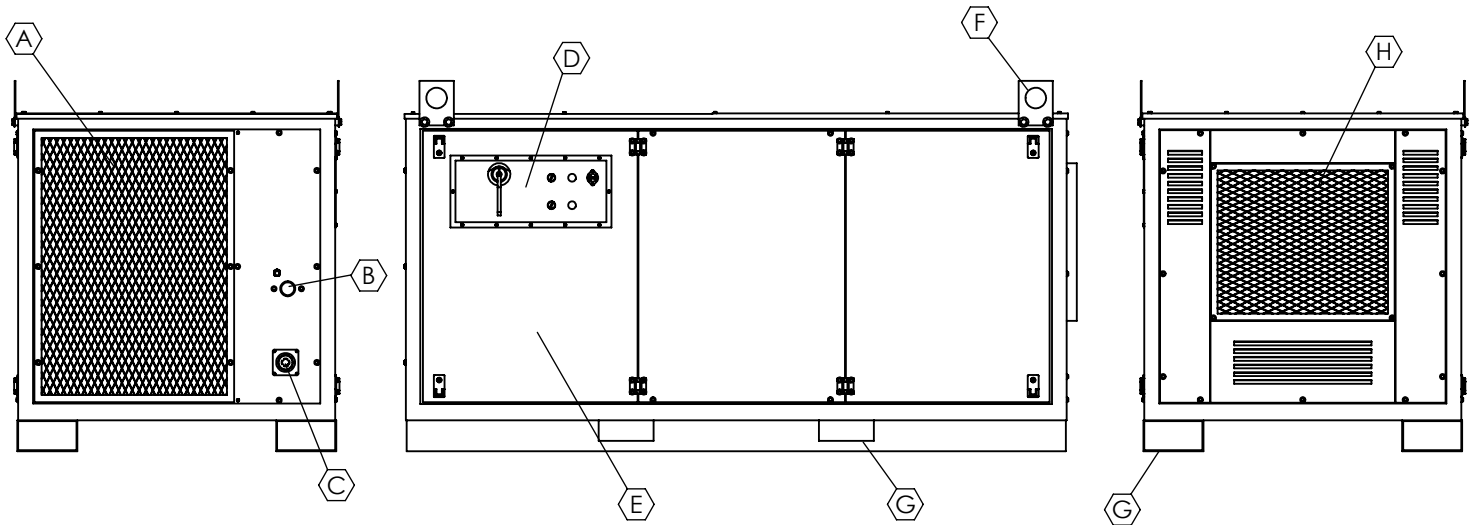

FMA-2300



SPECIFICATIONS:

POWER SUPPLY	230V/1PH/60Hz/35A
HEAT CAPACITY	320,000 - 2,300,000 BTU/HR
AIR FLOW	15,000 CFM
AIR OUTLET	27" W X 23" H

FUEL SUPPLY: MAX INLET PRESSURE

NATURAL GAS	5 PSI
PROPANE	5 PSI
CONNECTION	1-1/2" NPT

- A INLET SCREEN
- B 1-1/2" GAS INLET
- C ELECTRICAL CONNECTION
- D CONTROL PANEL
- E SERVICE ACCESS DOOR
- F LIFTING EYES
- G FORK POCKETS
- H AIR DISCHARGE

DIMENSIONS:

LENGTH	98 in
WIDTH	48 in
HEIGHT	54 in
WEIGHT	1900 lbs

FUEL CONSUMPTION:

NATURAL GAS	2300 CFH
PROPANE	25.14 GPH