

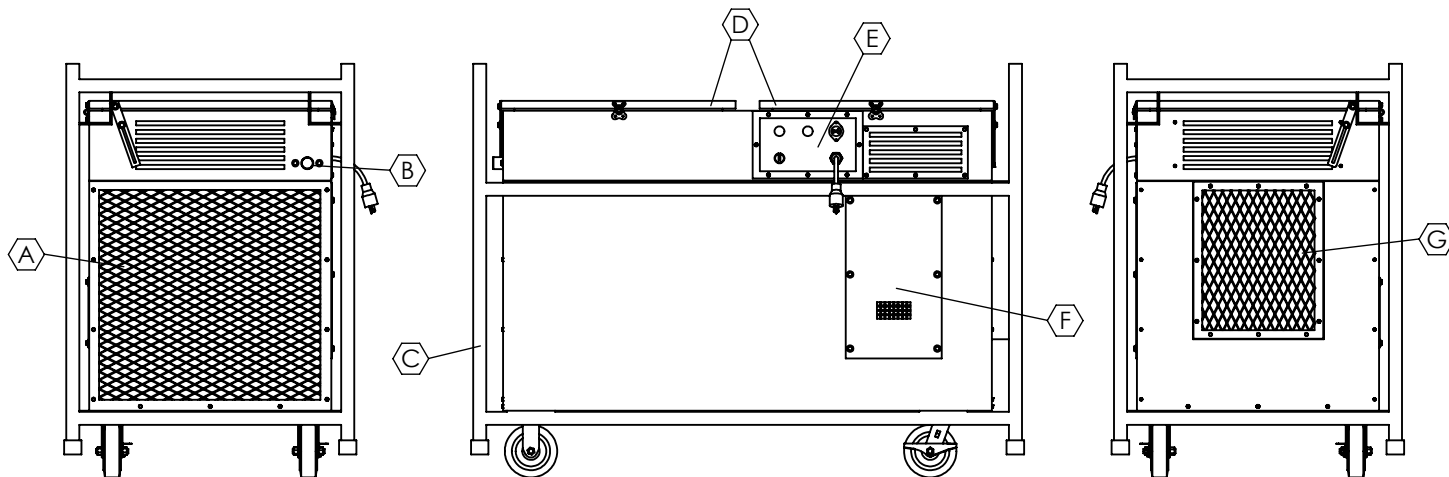

FMA-550



SPECIFICATIONS:

POWER SUPPLY	120V/1PH/60Hz/20A
HEAT CAPACITY	200,000 - 550,000 BTU/HR
AIR FLOW	4400 CFM
AIR OUTLET	15" W X 18" H

- A INLET SCREEN
- B 1" GAS INLET
- C PROTECTIVE STACKING FRAME
- D SERVICE ACCESS DOORS
- E CONTROL PANEL
- F BELT/BEARING ACCESS PANEL
- G AIR DISCHARGE

FUEL SUPPLY - MAX INLET PRESSURE:

NATURAL GAS	14" W.C.
PROPANE	14" W.C.
CONNECTION	1" NPT

DIMENSIONS:

LENGTH	63 in
WIDTH	33 in
HEIGHT	47.5 in
WEIGHT	590 lbs

FUEL CONSUMPTION:

NATURAL GAS	550 CFH
PROPANE	6.01 GPH